

Gas Pipes – VICUCLAD[®]:

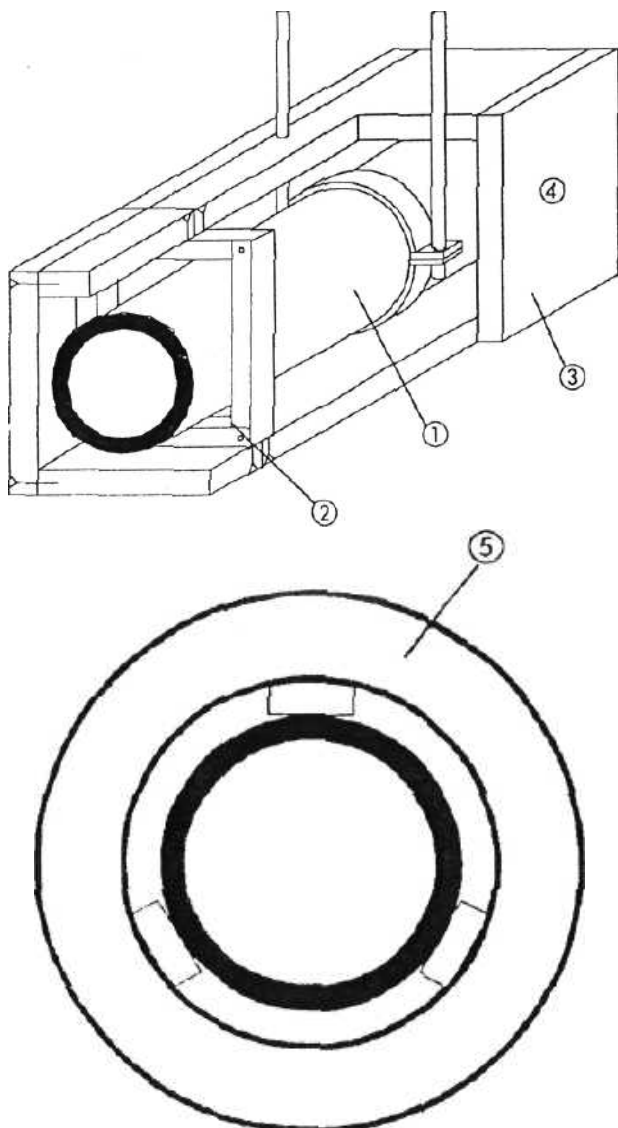

Guidance and requirements for the use of gas pipes can be found in Approved Document B (England and Wales), the Technical Standards (Scotland), Technical Booklet E (Northern Ireland) and the LPC Code.

- 1) Gas Pipe
- 2) An adequate gap should be left between the pipe and the encasement to allow for ventilation. The gap is typically about 13mm, but this should be confirmed with the relevant authorities for each installation. Gap can be simply formed using strips of VICUCLAD[®] as spacers, or with light gauge steel channel forming a frame for the casing.
- 3) To ensure the encasement is gas tight, at least two coats of LPL Firecheck (for gas pipes internal

to the building) or LDL Decadex (for gas pipes external to the building), should be applied over the whole of the external surface of the casing.

- 4) VICUCLAD[®] encasement - Boards bonded with VICUBOND[®] WR, and nailed at 300mm centres to each other. Nail length at least twice the board thickness.

The required board thicknesses are given in the table below.

Fire Resistance Period (minutes)	VICUCLAD [®] Thickness (mm)
30	18
60	25
90	30
120	35
180	45
240	55

- 5) As an alternative to VICUCLAD[®], VICUTUBE[®] can be used with the following minimum wall thicknesses.

Up to 90 minutes	30mm
Up to 120 minutes	40mm

LPL Firecheck and LPL Decadex are available from:

Liquid Plastics Limited, Astral House,
PO Box 7, Miller Street, Preston,
Lancs. PL1 1EE
Tel: 01772 259 781
Fax: 01772 882 016

This document can be used as part of a complete Method Statement that should be prepared by the installer. It describes the standard installation details. The installer should consult the Promat Technical Services Department for situations and details not covered in this document - or in Promat literature.

1. Check that the pipe run is suitably supported by steel brackets, which are adequately secured to a supporting structure and has at least the same fire resistance as is required by the VICUTUBE[®] encasement. This will vary with the size of the pipe, etc, but will generally mean that vertical pipes should have lateral support brackets at least every 3m, and horizontal pipes should have hangers every 1.2m. If vertical encasements exceed 15m in height, they will generally require additional support for the VICUTUBE[®] encasement at maximum 15m centres. If a vertical encasement does not rest on the ground at its base, then the base of the encasement should be supported by a suitable support framework, adequately secured to a nearby structure that has at least the same fire resistance.

AUTHORITY: Promat Recommendation

Technical Data Sheet – 022

Page 1 of 2
(Dec 2003)



Promat UK Limited
Technical Services Department
The Sterling Centre, Eastern Road
Bracknell, Berkshire RG12 2TD
Tel: 01344 381 400
Fax: 01344 381 401
E-mail: technicaluk@promat.co.uk



The framework should be designed such that the stress on each of its members does not exceed 18N/mm² (30 minutes), or 10N/mm² (up to 120 minutes).

2. Consult the relevant gas authority for the building to determine the minimum acceptable ventilation gap size between each pipe and the inner surface of the VICUTUBE[®]. This gap should be ventilated to outside the building. Refer to the Promat Technical Services Department and/or Promat literature to determine the appropriate VICUTUBE[®] section for the fire resistance period required by the approval authorities.
3. Select and prepare suitable non-combustible spacer strips to fit between the VICUTUBE[®] and the pipe. These will typically be cut pieces of VICUTUBE[®], at least 100mm long, located at three or four positions around the circumference of the pipe, coincident with every joint between lengths of VICUTUBE[®]. All strips should be positioned such that the continuous ventilation gap is not blocked. To ease installation, the spacer strips can be adhered to the pipe with VICUBOND[®] before securing the VICUTUBE[®]. The thickness of the strips should be such that the main VICUTUBE[®] encasement will fit tightly against them.
4. Apply VICUBOND[®] adhesive continuously to the edges of one of the VICUTUBE[®] sections. The line of adhesive should be continuous, and located more towards the outer surface of the VICUTUBE[®], to ensure that little or no excess adhesive is extruded into the ventilation gap when the two sections are mated together.
5. Position the VICUTUBE[®] section around the pipe, and offer up a second VICUTUBE[®] section, which has not been glued, against the first section. Slightly rubbing the two surface together assists in achieving a good seal. To ensure the two parts remain together while the adhesive sets, (approximately 2 to 4 hours), wrap tape, wire, or straps around the sections.
6. Check that excess adhesive has not restricted the ventilation gap, and remove excess adhesive from the outer surface with an upward cutting action, while it is still wet.
7. Apply VICUBOND[®] to the ends of the first length of completed VICUTUBE[®], and then install the next VICUTUBE[®] lengths as above. The end of each VICUTUBE[®] section that abuts an adjoining wall, or rests on a floor slab, should also be sealed by fully filling the joint with VICUBOND[®].
8. Carefully cutting the VICUTUBE[®] sections with mitred joints, and filling the joints with VICUBOND[®] as above, can encase bends in pipes. Larger VICUTUBE[®] sections, or flat VICUCLAD[®] board, may be preferred for practical reasons. As elsewhere, care should be taken to ensure that an adequate, ventilated gap is left at these points.
9. Check that all the joints are continuously filled with VICUCLAD[®] after at least 2 hours, ideally to the full depth of the joint, (but at least for 75% of the joint depth). Any gaps should be filled with Vicubond. The joint width should be between 1 to 4mm.
10. If the encasement is penetrated by steel brackets, or a pipe branch, the VICUTUBE[®] should be cut to fit tightly around the brackets or branch pipe, and any remaining gaps sealed with VICUBOND[®]. If the gaps exceed 4mm in width, they should be sealed for their full depth with PROMASEAL[®] Intumescent Sealant, up to a maximum joint width of 35mm. For gaps wider than 35mm, the gap should be covered with VICULACD[®] or VICUTUBE[®] sections, carefully bonded to the main encasement. Any remaining gaps should be filled as detailed above.
11. Apply at least two coats of Firecheck or Decadex, Coating from Liquid Plastics Ltd., in accordance with the manufacturer's instructions, (the LPL primer is not required). Depending on ambient conditions, it is generally advisable to apply the coatings at least 24 hours after the VICUTUBE[®] has been installed.
12. In areas that may be subject to physical damage, it is advisable to incorporate an LPL glass fibre matt within the LPL coatings, in accordance with the manufacturer's instructions, and/or to display warning notices both during and after installation.
13. Refer to the appropriate gas authorities to ensure that the appropriate signage is applied for enclosed gas pipes.
14. Once the VICUTUBE[®] system is installed, ensure that any remaining gaps in fire-resisting walls, partitions or floors, are sealed with a suitable Promat fire stopping system. The Promat Technical Services Department can advise on suitable systems. Please note that the VICUTUBE[®] encasement should normally be continuous, i.e. it should **not** be stopped either side of walls, partitions, or floors.
15. It is advisable to check the gas tightness of each run of encased pipe, by temporarily sealing the ends of the encasement and creating a pressure similar to the maximum expected pressure that will occur in the pipe. If the Vicutube enclosure did not maintain the required pressure, passing smoke into the system with the end still sealed can help to identify leaks.

In addition, to ensure that the ventilated gap is not restricted, the end of the enclosure should remain unsealed, and a smoke test carried out. Smoke entering near the beginning of the pipe run, should be seen to exit at the end of the run in reasonable quantities.